

# AUTOMATIC ICE MAKER INSTALLATION INSTRUCTIONS

An authorized service technician is recommended to install the ice maker kit.



## WARNING

- To avoid electric shock, which can cause death or severe personal injury, disconnect the refrigerator from electrical power before connecting a water supply line to the refrigerator.
- Connect the ice maker to a potable water supply only.

### Tools Needed:

• Electric drill with ¼" bit	• Adjustable wrench
• Putty knife	• Knife Gloves
• Needle nose pliers or nut driver	• Flat head screw driver
• Phillips or Quadrex driver	

NSF/ANSI/CAN 61: Q ≤ 1

## Ice Maker (IMKT2026) Kit Components

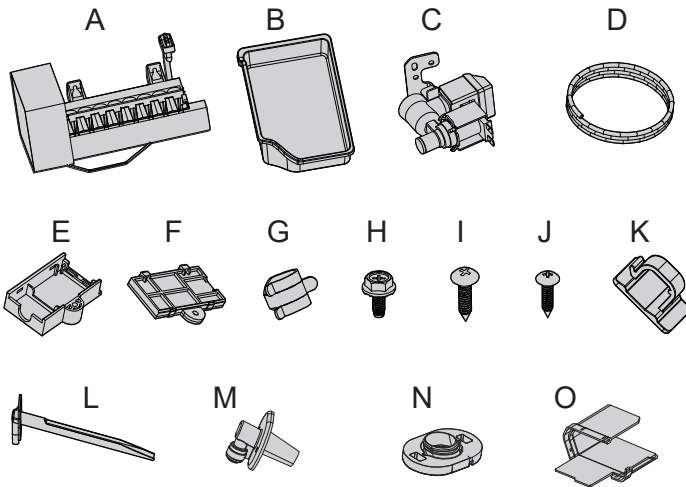

Part	Description	Qty.
<b>A</b>	Ice Maker	1
<b>B</b>	Ice Storage Bin	1
<b>C</b>	Water Valve	1
<b>D</b>	Plastic Water Supply Tubing	1
<b>E</b>	Mounting Box	1
<b>F</b>	Box Cover	1
<b>G</b>	Tube Clamp	1
<b>H</b>	Leveling Bracket Screw	1
<b>I</b>	Ice Maker Mounting Screws	2
<b>J</b>	Self-tapping Screws	3
<b>K</b>	Plastic Clamps	3
<b>L</b>	Water inlet tube 1 ( Top Mount Freezer only )	1
<b>M</b>	Water pipe joint ( Bottom Mount Freezer only )	1
<b>N</b>	Sealed silica gel block ( Bottom Mount Freezer only )	1
<b>O</b>	Connecting plate 1 ( Bottom Mount Freezer only )	1

# Ice Maker Installation Instructions

## → IMPORTANT

This kit contains two water inlet tubes for two different applications. To install this ice maker kit, ensure you are using the water inlet tube with the shorter hose and the screw holes are closer together. Match the screw holes up with the holes on the back of the cabinet.

## ! WARNING

Unplug the refrigerator from the electrical outlet. Remove the glass freezer shelf and Ice tray before you begin.

1. Remove the plug from the inside of the freezer compartment with a putty knife.

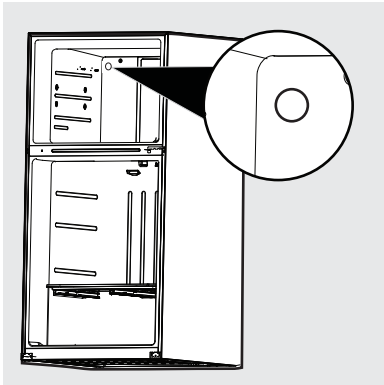

2. Remove the label covering the ice maker hole on the back of the unit, and then remove the foam from inside the hole using needle nose pliers. Keep the foam for future use. See Figure 2.

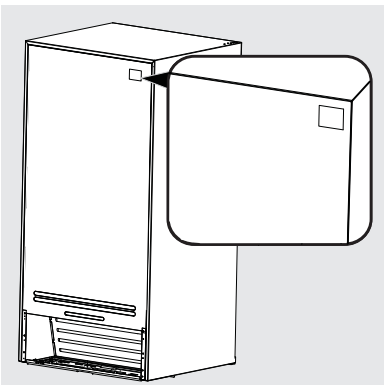

3. Insert the water inlet tube by rotating it into the hole located on the inside of the unit until the flat surface of the inlet tube is tight against the back of the cabinet. Secure the water inlet tube to the back of the cabinet using two self-drilling screws. See Figure 3.

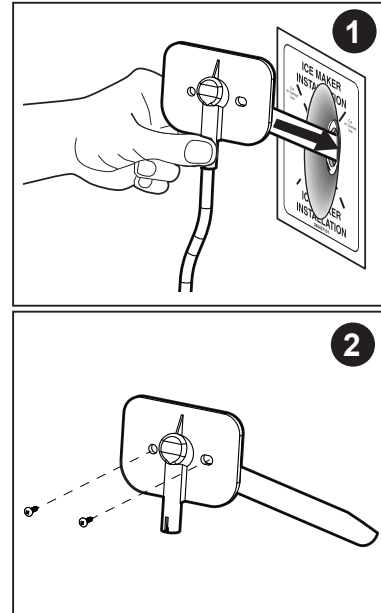

4. While squeezing the tube clamp, slide the clamp over the full tube. While still squeezing the clamp, insert one end of the plastic tube into the fill tube as far as it will go, and then slide the clamp down to keep the fill tube in place. Push the plastic tube in as far as it will go, and put the tube clamp in place over the fill tube to avoid leaks.

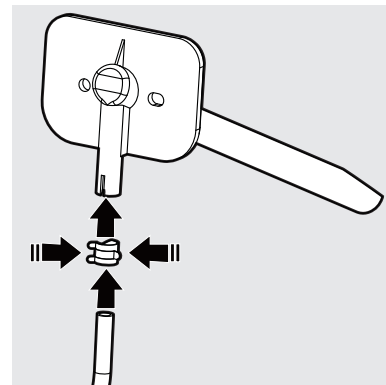

## Ice Maker Installation Instructions

5. Insert two ice maker mounting screws into the holes in the freezer wall. Turn each screw clockwise five times.

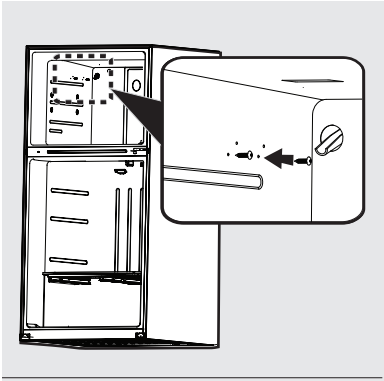

6. Using the needle nose pliers, remove the internal cover located on the inner ceiling of the freezer by first pulling down one side of the cover, and then pulling down the other side. Save the terminal cover for future use in case you remove the ice maker.

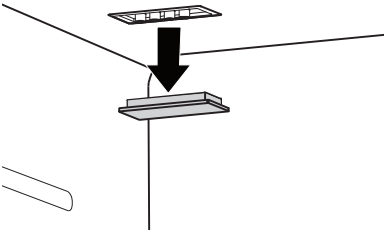

7. Holding the ice maker with one hand, plug the wiring harness connector into the terminal located at the top of the freezer panel. Make sure the connection is tight. Make sure the wiring harness is still in the hook on the back of the ice maker.

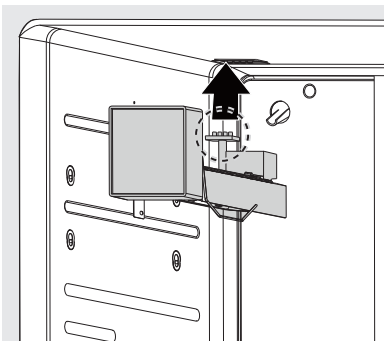

8. Mount the ice maker onto the two ice maker mounting screws you installed in step 5. Make sure the water inlet tube is sitting inside the fill cup and the ice maker is level, and then tighten the screws.

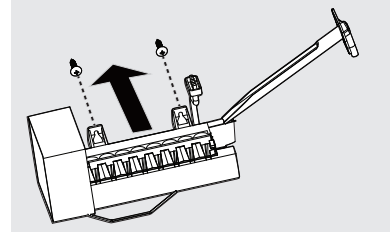

9. Reinstall the freezer shelf, and place the ice storage bin on the shelf.

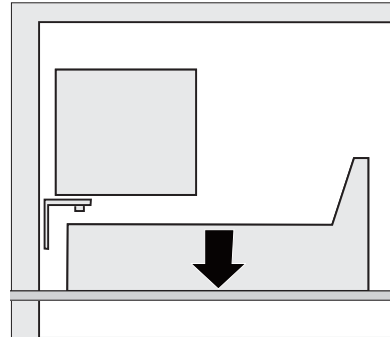

10. Connect the wiring harness to the water valve, making sure the connection is tight, and then install the mounting box and box cover on the plug.

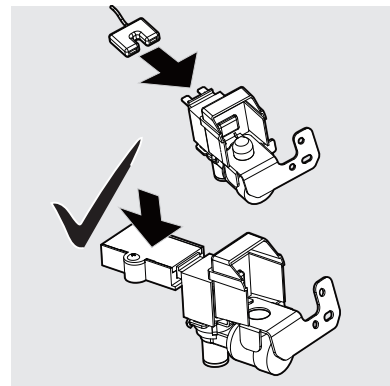

## Ice Maker Installation Instructions

11. Locate the pre-punched holes at the bottom right corner of the back panel of the refrigerator. Align the water valve bracket with the factory-drilled holes, and then use a Phillips screwdriver to drive the two self-drilling screws through the bracket and into the cabinet.

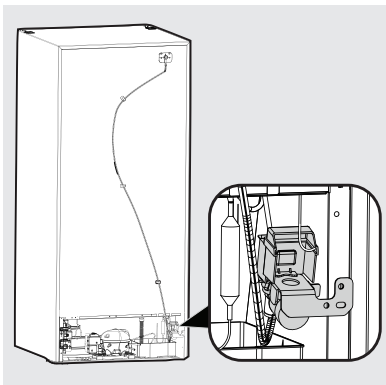

13. Clean the back of the cabinet with a commercial household cleaner, ammonia, or alcohol before applying the clamps. Secure the plastic water supply tubing to the back of the cabinet with three plastic clamps.

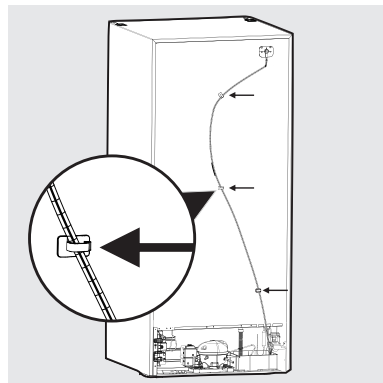

12. Grasp the other end of the plastic tube, and firmly push it into the quick connection on the valve until it bottoms out.

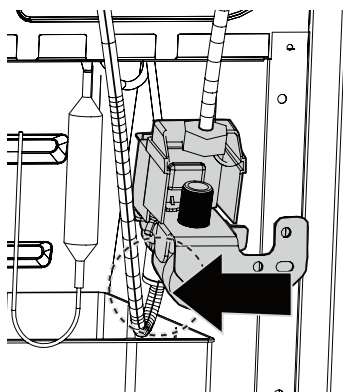

# Installation Instructions - ( Bottom mount freezer )

## 1 Remove the drawers and freezer compartment door

- Remove the drawers from the freezer compartment. Remove the small screw on each guide rail of the freezer compartment door, then remove the freezer compartment door, with the guide rail support, from the guide rail.

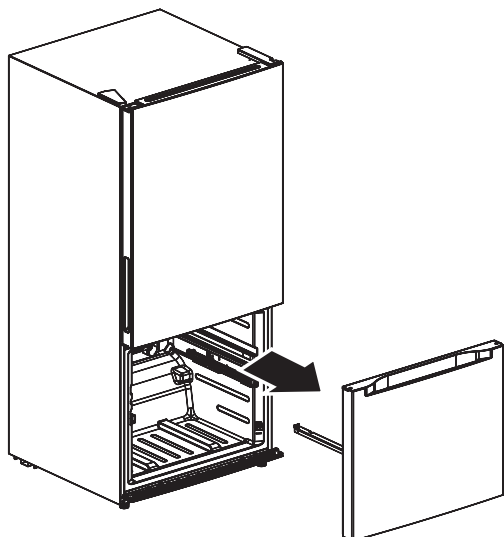

## 2 Insert the connection plate into the ice maker unit

- Remove the ice maker unit and the connection plate from the accessories bag, then insert the connection plate into the ice maker unit (as shown below) by aligning the connection plate with the notch in the ice maker unit.

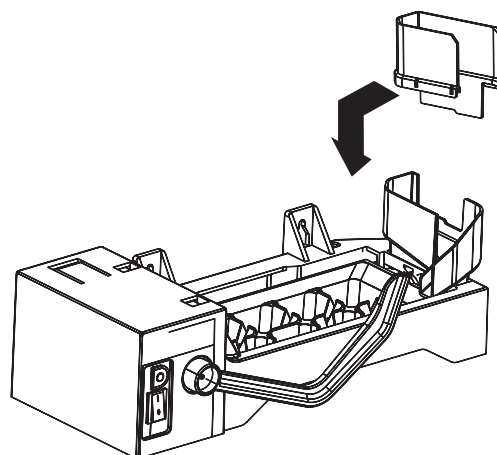

## 3 Remove connector cover and ice maker mounting screws fixed

- Remove the connector cover from the upper left corner of the freezer compartment, then remove the ice maker mounting screws from the accessory bag and attach them loosely to the two mounting holes in the back of the freezer compartment.

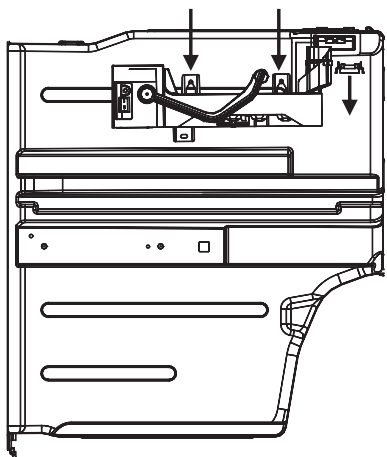

## 4 Fixed ice maker

- Insert the power connector of the ice maker into the socket in the freezer compartment, then loosely mount the ice maker onto the ice maker mounting screws. Move the ice maker to the left as far as it will go, then align it vertically and tighten the ice maker mounting screws.

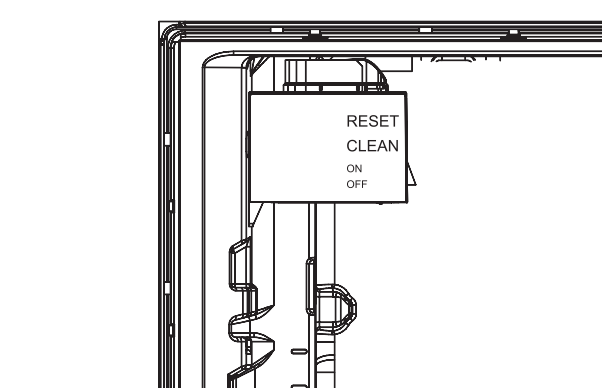

# Installation Instructions - ( Bottom mount freezer )

## 5 Reinstall the drawers and freezer compartment door

- Reinstall the freezer door guide rail and freezer drawers, then place the ice storage bin in the top freezer drawer.

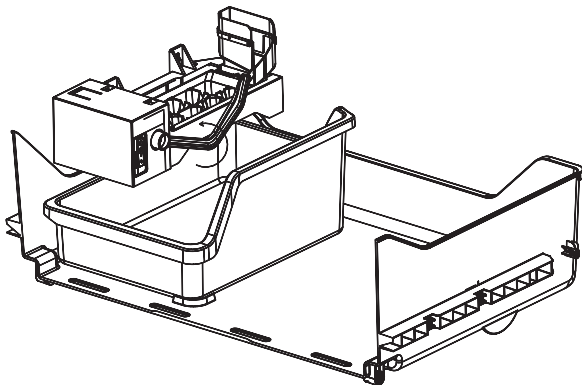

## 6 Remove the label and then remove the foam

- To install the Ice maker fill tube, peel off the label on the back of your refrigerator.

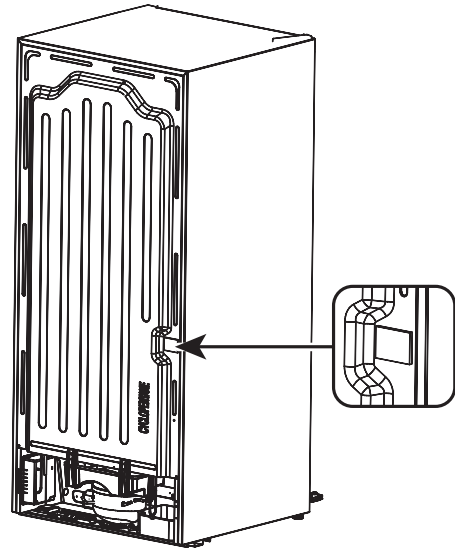

## 7 Remove the thermal insulation foam strip

- Use needle nose pliers to remove the thermal insulation plug from the hole you just exposed.

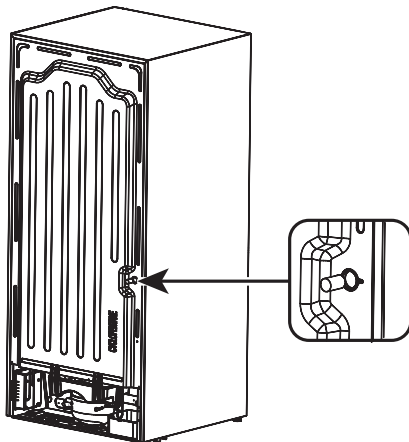

## 8 Fixed Sealed silica gel block and water pipe joint

- Remove the water tube connector, silicone seal, long water supply tube, and white head screw from the accessory bag, then assemble the parts by aligning the notch on the silicone seal with the notch on the water tube connector, inserting one end of the water supply tube into the quick change sealing ring at the bottom of the connector. Make sure that all parts are securely assembled. Insert the water supply assembly into the water inlet hole on the back of your refrigerator, and secure it with the long screw from the accessory bag.

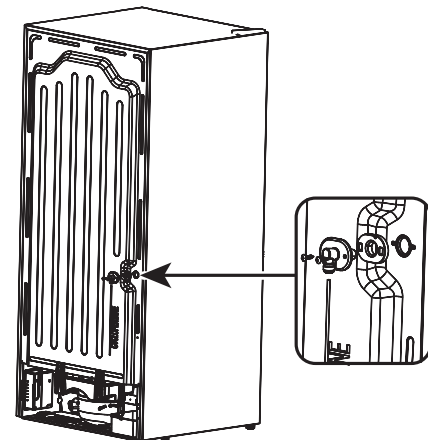

# Installation Instructions - ( Bottom mount freezer )

## 9 Fixed water valve

- Locate the pre-punched holes at the bottom right corner of the back panel of the refrigerator. Align the water valve bracket with the factory drilled holes, then use a Phillips head screwdriver to drive the two self-drilling screws through the bracket and into the cabinet.

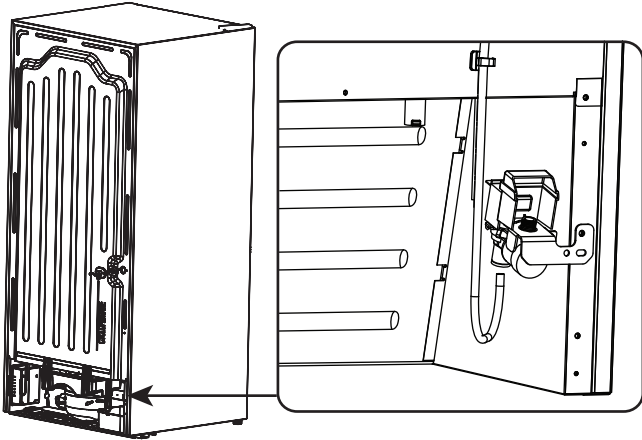

## 10 Connect the wiring harness to the water valve

- Connect the wiring harness to the water valve, making sure that the connection is tight, then install the mounting box and protective cover over the plug for the valve.

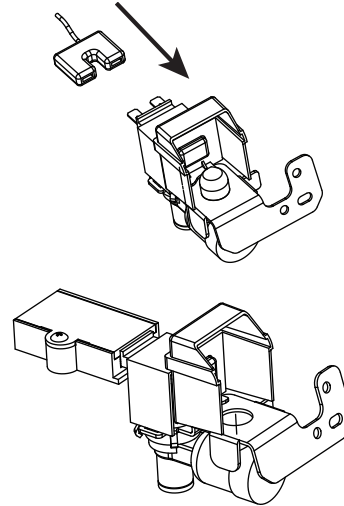

## 11 Water valve and plastic water supply tubing connection

- Insert the plastic tube end into the quick connection of the water valve, push into as far as it will go.

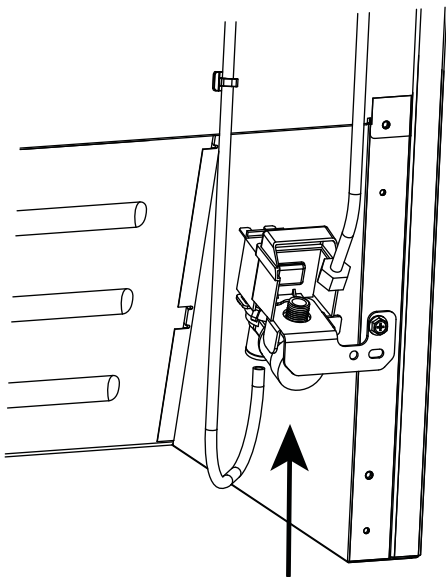

## 12 Plastic water supply tubing fixed

- Clean the back of the cabinet with a commercial household cleaner, ammonia, or alcohol before applying the clamps. Loop the tubing and secure to the back of the cabinet using the three plastic clamps.

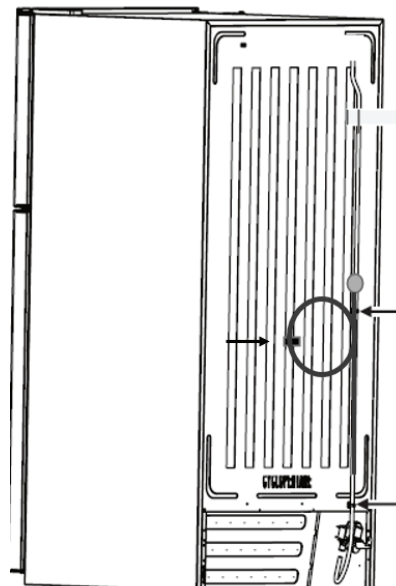

## Connecting Ice Maker to Water Supply



### WARNING

To avoid electric shock, which can cause death or severe personal injury, disconnect the refrigerator from electrical power before connecting a water supply line to the refrigerator.



### CAUTION

#### To Avoid Property Damage:

- Stainless Steel braided tubing is recommended for the water supply line. Water supply tubing made of 1/4" plastic is not recommended to be used. Plastic tubing greatly increases the potential for water leaks, and the manufacturer will not be responsible for any damage.
- DO NOT install water supply tubing in areas where temperatures fall below freezing.
- Chemicals from a malfunctioning softener can damage the ice maker. If the ice maker is connected to soft water, ensure that the softener is maintained and working properly.



### IMPORTANT

Ensure that your water supply line connections comply with all local plumbing codes.

#### Before Installing The Water Supply Line, You Will Need:

- Basic Tools: adjustable wrench, flat blade screwdriver, and Phillips screwdriver
- Access to a household cold water line with water pressure between 30 and 100 psi.
- A water supply line preferably made of Braided Stainless Steel or Braided Poly with integral fittings for connection to the refrigerator and the valve at the wall. If the home has a 1/4" copper line, and the owner prefers to keep the copper line, a compression fitting ferrule (sleeve) and nut should be replaced each time the fitting is reused.



### NOTE

Check with your local building authority for recommendations on water lines and associated materials prior to installing your new refrigerator. Depending on your local/state building codes, Frigidaire recommends for homes with existing valves its **Smart Choice**® water line kit 5304437642 (with a 6' Stainless Steel Water Line) and for homes without an existing valve, Frigidaire recommends its **Smart Choice**® water line kit 5304493869 (with a 6' Polyline Waterline). Please refer to Frigidaire.com.



### NOTE

Water lines should be long enough to allow the refrigerator to roll forward for cleaning or service. Typically, 6' length works well for braided Stainless or Poly kits. A 1/4" copper line should be longer to coil extra length behind the refrigerator so movement will not kink the copper line.

## Connecting Ice Maker to Water Supply

### To Connect Water Supply Line To Ice Maker Inlet Valve

1. Disconnect refrigerator from an electrical power source.
2. Place the end of water supply line into the sink or a bucket. Turn ON the water supply and flush the supply line until the water is clear. Turn OFF the water supply at the shutoff valve.
3. Remove the plastic cap from water valve inlet and discard the cap.
4. **If you use copper tubing**, slide the brass compression nut and then ferrule (sleeve) onto the water supply line. Push the water supply line into the water valve inlet as far as it will go ( $\frac{1}{4}$ " / 6.4 mm). Slide the ferrule (sleeve) into the valve inlet and finger tighten the compression nut onto the valve. Tighten another  $\frac{1}{2}$  turn with a wrench; DO NOT overtighten. See below.

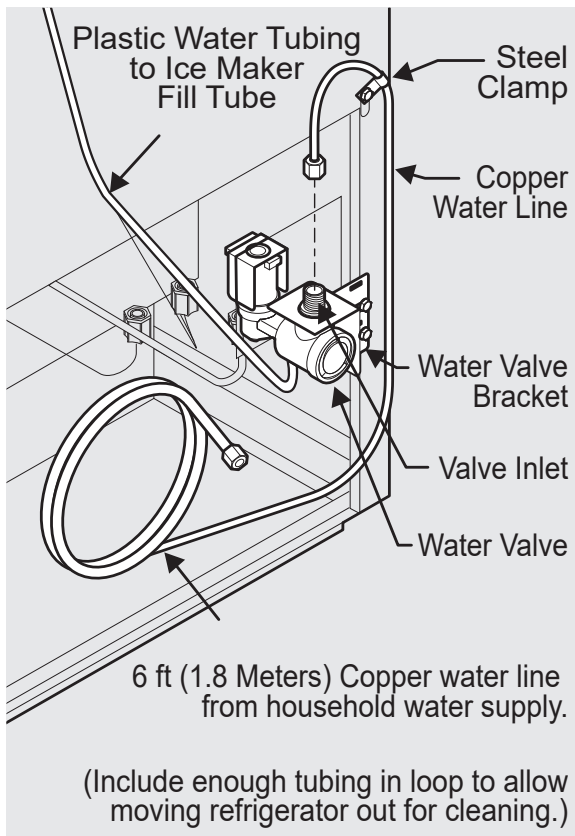

5. Secure the copper line to the clamp (as shown), using the existing screw.  
**If you use braided flexible stainless steel tubing**, the nut is already assembled on the tubing. Slide the nut onto the valve inlet and finger tighten the nut onto the valve. Tighten another  $\frac{1}{2}$  turn with a wrench; DO NOT overtighten. See below.

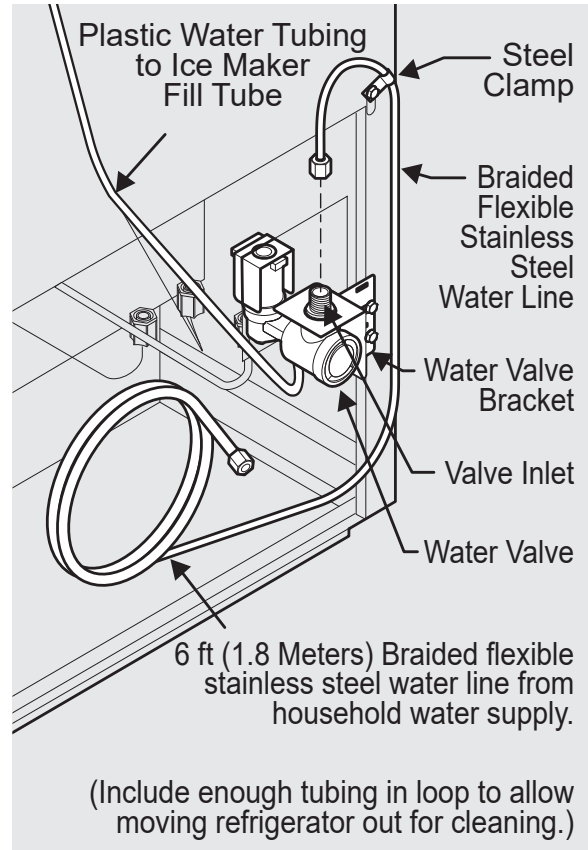

6. With the steel clamp and the screw, secure the water supply line to the rear panel of the refrigerator as shown.
7. To turn the ice maker on, press the ice maker's On/Off power switch.
8. Turn ON the water supply at the shutoff valve and tighten any connections that leak.
9. Reconnect the refrigerator to an electrical power source.