



Freezer

FFUH21F2NW

Frost Free
21 Cu. Ft. Upright



Product Dimensions

Height (Including Hinges)	71-3/8"
Width	32"
Depth (Including Door)	28-5/8"

More Easy-To-Use Features

Adjustable Temperature Control
Select the correct temperature for your needs.

Colour-Coordinated Handle

ENERGY STAR®



Available in:



White
(W)

Signature Features

Frost Free Operation

Never defrost your freezer again.

ENERGY STAR® Qualified

Bright Lighting

Our bright lighting makes it easy to see what's inside.

Lock with Pop-Out Key

The freezer key automatically ejects after locking the door so you won't leave it in the door.

Features	
Door Handle Design	Reach-Through
Reversible Door	
Automatic Door Closer	Yes
Leveling Legs	Yes
Lock with Pop-Out Key	Yes
Defrost	Frost Free
Adjustable Temperature Control	Mechanical Dial
Front Digital Display	
Temp Display Mode	
High-Temp Duration Readout	
High-Temp Alarm	
Door Ajar Alarm	
Airflow Ports	1
Interior Lighting	Bright
Full-Width Adjustable Shelves	
Full-Width Fixed Shelves	4 Wire
Removable Trivet	1
SpaceWise® Shelf Bookend	
Mid-Level Baskets	
Lower Storage Basket	
Basket Dividers	
Retractable Pizza Shelf	
Soft Freeze™ Zone	
Store-More™ Adjustable Door Bins	
Full-Width Door Bins	
Store-More™ Tilt-Out Wire Door Bins	
Fixed Door Racks	6
Defrost Drain	
Power-On Light	
Convertible	
Certifications	
ENERGY STAR®	Yes
CSA Rating	Household
Specifications	
Total Capacity (Cu. Ft.)	20.5
Shelf Area (Sq. Ft.)	19.69
Annual Energy (kWH)	690
Annual Energy Cost (.1065/kWH)	\$73
Power Supply Connection Location	Lower Right Rear
Voltage Rating	120V
Connected Load (kW rating) @ 120 Volts¹	.6
Amps @ 120 Volts	5
Minimum Circuit Required (Amps)	15
Shipping Weight (Approx.)	240 Lbs.

¹An electrical supply with grounded three-prong receptacle is required. The power supply circuit must be installed in accordance with current edition of National Electrical Code (NFPA 70) and local codes & ordinances.

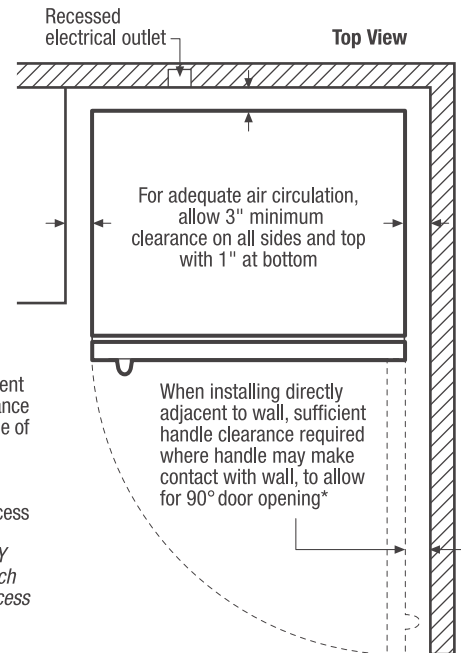
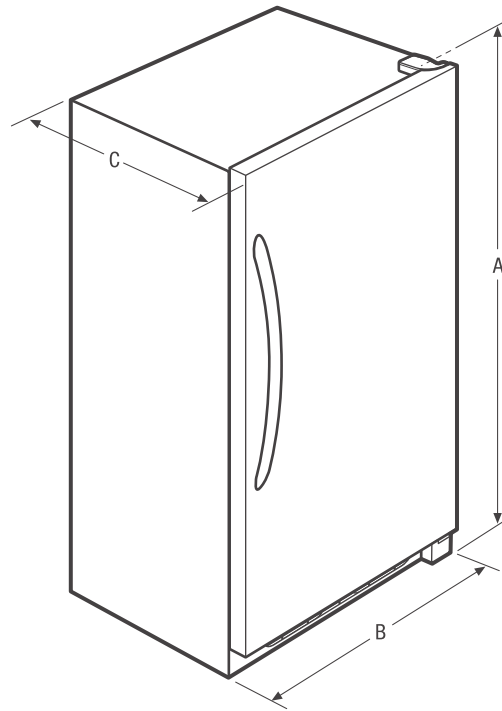

* When installing freezer adjacent to wall, cabinet or other appliance that extends beyond front edge of unit, 20" minimum clearance recommended to allow for optimum 140° door swing, providing complete basket access and removal. (Absolute 3" minimum clearance will ONLY allow for 90° door swing which will provide limited basket access with restricted removal.)

NOTE: For planning purposes only. Always consult local and national electric codes. Refer to Product Installation Guide for detailed installation instructions on the web at frigidaire.ca.



Product Dimensions	
A - Height (Including Hinges)	71-3/8"
B - Width	32"
C - Depth (Including Door)	28-5/8"
Depth with Door Open 90°	59-3/8"

Accessories information available on the web at frigidaire.ca