

FRIGIDAIRE®

All about the

Use & Care

of your Coffee Maker

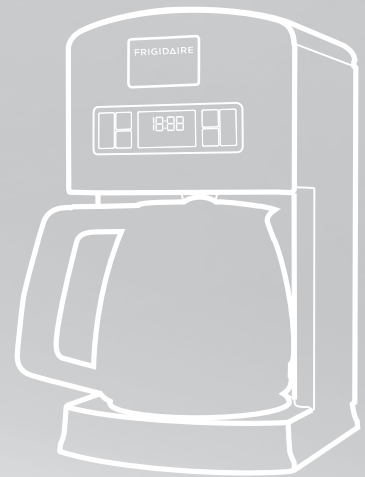

TABLE OF CONTENTS

Important Safeguards.....	2	Replacement Parts	7
Coffee Maker Safety Instructions.....	2	Brewing Tips.....	8
Parts and Features	3	Cleaning the Coffee Maker.....	8
Installing the Water Filter Holder and the Water Filter...6		Troubleshooting	8
Brewing Your First Pot of Coffee	7	Major Appliance Warranty	9

Register via the internet at: www.frigidaire.com/productregistration

USA and Canada 1-888-845-7330

IMPORTANT SAFEGUARDS

When using electrical appliances, basic safety precautions should always be followed, including the following:

- 1 Read all instructions before use.
- 2 Do not touch hot surfaces. Use handles or knobs.
- 3 To protect against electrical shock, do not immerse cord, plugs, or Coffee Maker in water or other liquid.
- 4 Close supervision is necessary when any appliance is used by or near children.
- 5 To prevent electric shock, unplug Coffee Maker from outlet when not in use and before cleaning. Allow to cool before putting on or taking off parts.
- 6 Do not operate any appliance with a damaged cord, plug. If the appliance malfunctions, or has been damaged in any manner, return the appliance to the nearest authorized service center for inspection, repair, or adjustment.
- 7 The use of an accessory not evaluated for use with this appliance may cause injuries.
- 8 Do not use outdoors.
- 9 Do not let cord touch hot surfaces or hang over edge of table or counter where it can be pulled on by children or tripped over unintentionally.
- 10 Do not place on or near a hot gas or electric burner, or in a heated oven.
- 11 Do not use appliance for other than intended use.
- 12 Do not use appliance without lid properly placed on container (carafe).
- 13 The container (carafe) is designed for use with this appliance. It must never be used on a range top or in a microwave oven.
- 14 Do not set a hot container (carafe) on a wet or cold surface.
- 15 Extreme caution must be used when moving an appliance containing hot oil or other hot liquids.
- 16 Do not use a cracked container (carafe) or a container having a loose or weakened handle.
- 17 Do not clean container with abrasive cleaners, steel wool pads, or other abrasive material.
- 18 This product is designed for household use only.
- 19 To disconnect, press the Brew On/Off button until the unit is turned off. Then remove the plug from the wall outlet.
- 20 To reduce the risk of fire or electric shock, do not remove the bottom cover. No user serviceable

parts inside. Service and repair should only be performed by an authorized service provider.

SAVE THESE INSTRUCTIONS

Consumer Safety Information

THIS UNIT IS FOR HOUSEHOLD USE ONLY.

Polarized Plug

This appliance has a polarized plug (one blade is wider than the other). To reduce the risk of electric shock, this plug will fit in a polarized outlet only one way. If the plug does not fit fully into the outlet, reverse the plug and reinsert. If it still does not fit, contact a qualified electrician. Do not modify the plug in any way.



CAUTION

Short Cord Instructions: Your Coffee Maker appliance is fitted with a short power supply cord as a safety precaution to prevent personal injury or property damage resulting from pulling, tripping or becoming entangled with a longer cord. Do not allow children to use or be near this appliance without close adult supervision. Longer extension cord is available and may be used if care is exercised in its use. If an extension cord is used, (1) the marked electrical rating of the cord set or extension cord should be at least as great as the electrical rating of the appliance, (2) the cord should be arranged so that it will not drape over the countertop or tabletop where it can be pulled on by children or tripped over. To reduce the risk of injury, do not drape cord over the counter top or table top where it can be pulled on by children or tripped over unintentionally.

Product Specifications

- | | |
|--|--------------|
| <input type="checkbox"/> Model Number | FPAD12D7PS |
| <input type="checkbox"/> Volts | 120V AC only |
| <input type="checkbox"/> Rated Wattage | 1100 Watts |
| <input type="checkbox"/> Hertz | 60Hz |
| <input type="checkbox"/> Made in China | |

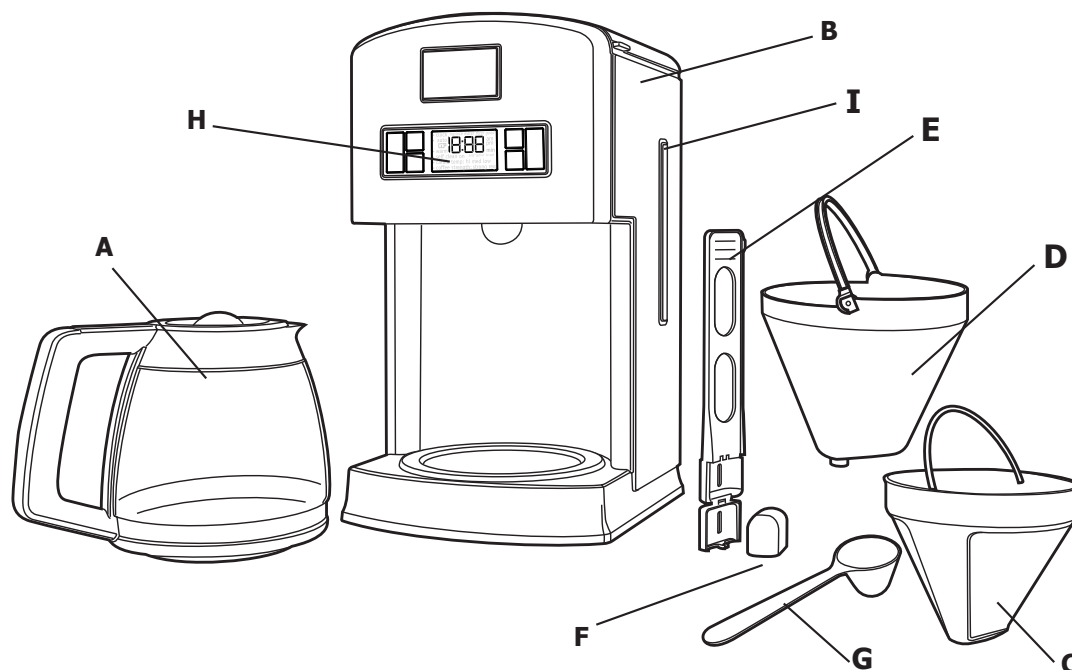

- A** Glass Carafe
- B** Water Tank/Brew Basket Lid
- C** Permanent Gold-Tone Filter
- D** Filter Basket
- E** Water Filter Holder
- F** Active Carbon Filter Cartridge
- G** Pre-Measured One-tablespoon Coffee Scoop
- H** Control Panel
- I** Water Level Indicator Window

Glass Carafe With Attached Lid

The Frigidaire Coffee Maker comes with a 12-cup glass carafe with an attached lid for easy pouring. The lid also helps keep foreign objects from getting inside the carafe.

Digital LCD Panel

The LCD panel provides accuracy and easy access to your personal settings. The panel also displays the current time and AM/PM indicators. To save energy, the display will dim after about 20 seconds. To brighten the display, simply press any button, (except the Brew On/Off button which will activate the LCD and begin the brewing process).

Pause to Pour Filter Basket

A sealed stopper in the Filter Basket allows you to remove the carafe before the brewing cycle is complete. It is recommended that you return the carafe to the

warming plate within 30 seconds to prevent an overflow from the Filter Basket becoming too full.

Permanent Gold-Tone Filter

The reusable Gold-Tone Filter eliminates the need for paper filters. However, if paper filters are preferred, use #4 cone filters. To prevent overflowing, do not use paper filters and the Gold-Tone filter at the same time.

Active Carbon Water Filter and Water Filter Holder

Quality water is an important component to great tasting coffee. The Active Carbon water filter helps eliminate chlorine, calcium, bad tastes and odors from ordinary tap water.

Water Level Indicator Window

Brew 2 to 12 cups using the water level indicator to easily pour the desired amount of water.

DISPLAY AND CONTROL PANEL

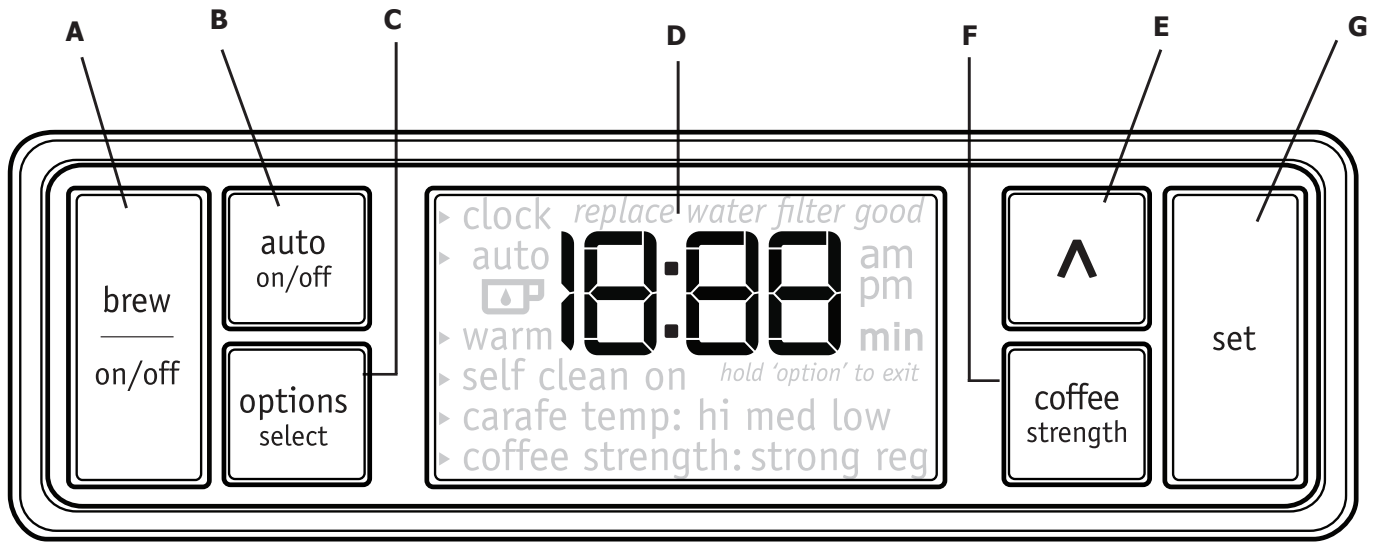

- A** Brew On/Off
B Auto On/Off

- C** Options Select
D LCD Display

- E** Menu Up-arrow
F Coffee strength
G Set

Brew On-Off Button

The Coffee Maker features one touch brewing that will begin brewing by pressing the Brew on-off button whether the LCD is active or in standby mode. To turn off the Coffee Maker, press the Brew On/Off button again.

Option Select

Press the Option Select button to cycle through the following options:

Set Clock:

- 1 To set the clock, press the Option Select button until the display reads Clock. Then, press the up-button to set the current hour. Once the hour is correct, press the Set button.
- 2 Press the up-button to select the current minute setting. Once again, press the Set button.
- 3 Press the up button to select either AM or PM, and then press Set to complete the clock setting process.
- 4 To exit the Options menu, press and hold the Option Select button.

Auto:

- 1 To set the auto start timer, press the Option Select button until the display reads Auto. Then, press the up-button to set the hour. Once the hour is correct, press the Set button.
- 2 Press the up-button to select the desired minute setting. Once again, press the Set button.
- 3 Press the up-button to select AM or PM. Press the set button.
- 4 Press and hold the Option Select button to exit the Options menu.
- 5 Now that the Auto time is set, press the Auto on-off button to turn the feature on. The auto timer is now set and will begin brewing at the designated time. To turn the Auto feature off, press the Auto on-off button again.

Warm:

- 1 To set the amount of time that the warming plate remains on, press the Option Select button until the arrow points to "Warm".
- 2 Press the up-button to advance the timer in 10-minute intervals until the desired time is reached. The warming plate can be set to remain on for up to 120 minutes.
- 3 Press the Set button. The warming plate can be set

to remain on for up to 120 minutes or disabled by setting to zero.

- 4 Press and hold the Option Select button to exit the Options menu.

Self Clean:

- 1 To clean your Coffee Maker, Mix a 12-cup ratio consisting of 1/3 white vinegar and 2/3 water.
- 2 Pour the mixture into the reservoir.
- 3 Press the option Select button to enter the options mode. Continue pressing the Option Select button incrementally until the arrow is pointing to "Self Clean".
- 4 Press the up-arrow button. The LCD panel will indicate "Self Clean On".
- 5 Press the set button.
- 6 Press and hold the Option Select button to exit the Options menu.
- 7 Press the Brew On-Off button to begin the cleaning process.

During the Cleaning cycle, the Coffee Maker will fill the carafe to about 6 cups, and then rest as the cleaning solution soaks the water passageways and reservoir. This rest cycle will last about 30 minutes. The LCD panel will continue to flash "Self Clean On". Do not turn the Coffee Maker off during the cleaning cycle. After about 30 minutes, the cleaning cycle will process the remaining solution in the reservoir; the Self Cleaning process takes about 50 minutes to complete. Once the process has finished, an alert tone will sound. After disposing of the solution in the carafe, your Coffee Maker will then be ready for normal use.

Carafe Temp:

- 1 To set the temperature of the carafe warming plate, press the Option Select button. Continue incrementally pressing the Option Select button until the arrow is pointing to "Carafe Temp".
- 2 Press the up-arrow to select "High, Medium, or Low"
- 3 Press the Set button
- 4 Press and hold the Option Select button to exit the Option Select function.

Auto On-Off Button

Use this button to activate the Auto On-Off timer.

LCD Display

Displays various option settings, clock, and timer. Turn on the LCD by pressing any button except the Brew On/Off.

Pressing the Brew On/Off will also begin the brewing process.

Up-Arrow Button

Use this button to navigate the various options in the LCD panel and to adjust the timer and clock.

Coffee Strength

Use this button to set the coffee strength. Press once for Strong coffee, and a second time for Regular strength coffee.

INSTALLING THE WATER FILTER HOLDER AND CARBON FILTER

The supplied filter reduces many of the contaminants that can negatively affect the flavor of the coffee. Although the Coffee Maker will function normally without it, use of the filter is highly recommended.

- 1** The filter assembly consists of a Water Filter Holder, and an active carbon filter cartridge. Prior to inserting the cartridge into the holder, place the carbon filter cartridge into a container of clean cool water, and let soak. After 10 minutes, remove the cartridge from the container and thoroughly rinse under running tap water for 10 to 15 seconds. This will remove any carbon dust particles that could make their way into your first brew. This step is only necessary for new carbon filters. Repeat this procedure each time you replace the filter.

It is recommended that the carbon filter be replaced after each 60 brew cycles. A reminder on the LCD panel will alert you once you have reached the 60th brew cycle. To clear the reminder, simply press and hold the Set button until the alert disappears.

- 2** To install the filter, place the carbon cartridge into the Water Filter Holder cage, and snap the cage closed, locking the cartridge into the holder.
- 3** Lower the Water Filter Holder, filter end first, down into the bottom of the water reservoir and insert the holder into the pocket located at the bottom of the reservoir.

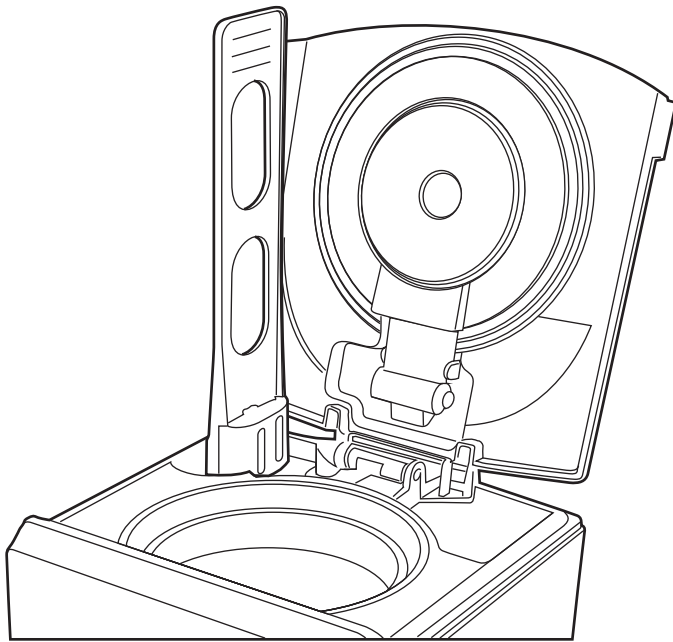

- 4** Plug the Coffee Maker into a grounded outlet. You should hear a short alert tone. Fill the reservoir with clean, cool water. Do not exceed 12 cups of water, as the overflow slots in the back of the reservoir will cause

the excess water to run out the back of the unit and on to the counter top.

If you are using a container other than the carafe to fill the reservoir, use the water level indicator window on the right side of the Coffee Maker to measure the desired amount of water.

- 5** Place the Filter Basket into position and lower the Permanent Gold-Tone filter into the basket - Do not add coffee at this time! Place the empty carafe onto the warming plate and press the On-Off button once to start the brewing process. Allow the Coffee Maker to cycle with water-only for the first use. The unit will sound three alert tones once the brewing process has completed. Discard the water from the break-in cycle.



NOTE





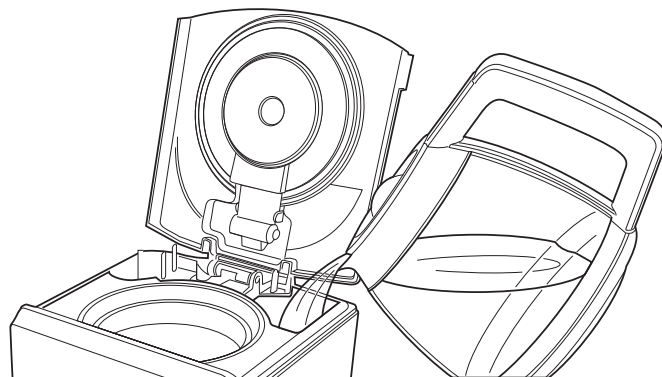

Repeat these steps each time you replace the carbon filter element.

BREWING YOUR FIRST POT OF COFFEE

- 1 Thoroughly wash the Filter Basket, the Permanent Gold-Tone Filter, the Water Filter Holder, and the carafe in hot soapy water. Rinse with clean water and dry. Do not use abrasive cleansers or scouring pads. Do not submerge the Coffee Maker in water or any other liquid, or permanent damage to the Coffee Maker will result!
- 2 Lift the reservoir lid on top of the Coffee Maker, and pour the desired amount of cool water into the reservoir. Be sure to pour the water into the reservoir, and not into the Filter Basket.
- 3 With the Filter Basket in place, insert the Permanent Gold-Tone Filter, or a #4 paper cone filter into the Filter Basket – but not both!
- 4 Add the desired amount of ground coffee into the filter. It is recommended that you start out using one tablespoon of ground coffee for every cup of water in the reservoir. However, you may adjust the amount of coffee to water ratio to suit your personal taste.
- 5 Press the On-Off button once to start the brewing process. Prior to pushing the On-Off button to begin brewing, you may want to adjust the strength setting by pressing the Coffee Strength button on the control panel. You may choose from Regular or Strong.
- 6 Once the brewing cycle has ended, 3 alert tones will sound.



REPLACEMENT PARTS

Frigidaire Accessories / Accesorios de Frigidaire / Accessoires de Frigidaire		Part No. N° De Parte / N° De Pièce
	Coffee Carafe Café Jarra Verseuse à Café	16157
	Carafe Lid Tapa Cafetera Couvercle de la Carafe	16160
	Filter Basket Holder Portafiltro tipo canasta Porte-Panier Filtre	16158
	Goldtone Coffee Filter Filtro Dorado Para Cafetera Filtre à Café Doré	16159
	Water Filter Holder Portafiltro De Agua Porte-Filtre à Eau	16164
	6-Pack Coffee Water Filters Filtro de agua, paquete de 6 Paquet De 6 Filtres à Eau	FPDC06WFMW
	Replacement Rubber Feet (4-Pack) Pies de Goma de Reemplazo (Conjunto de 4) Pieds en Caoutchouc de Remplacement (Paquet de 4)	16181-1

To order replacement parts in the U.S.A and Mexico, visit us online at www.frigidaire.com/professional

To order replacement parts in Canada, visit us online at www.frigidaire.ca

Or call us at 1-888-845-7330

Hours

Call Monday-Friday, 9 am-8:30 pm EST; Saturday and Sunday, 11am-7.30 pm EST. (Please call the same number for answers to problems or questions.)

For pricing, see our website www.frigidaire.com/professional or call 1-888-845-7330

BREWING TIPS, CLEANING, TROUBLESHOOTING

Use the Coffee Strength button to select Regular or Strong depending on your preference.

Use Fresh Coffee Beans

It is recommended that you grind your coffee before each brew, and use the freshest beans possible. Keep the beans in an airtight container, and store in a cool location. Do not refrigerate the beans, as condensation will likely form on the beans once they are removed from the refrigerator. Although freezing may help preserve the beans, the flavor could be negatively affected over time.

Grinding Your Coffee

Although pre-ground coffee is perfectly acceptable, the best coffee will come from fresh ground beans. It is recommended that you grind your beans immediately prior to brewing, and set your grinder to the medium grind level setting. Medium grind is the optimum setting for most automatic drip coffee makers.

How Much Coffee to Use For Each Pot

Depending on the desired strength of the coffee, a ratio of one tablespoon per cup is the recommended starting point. You may adjust this amount to suit your personal preference, but if you prefer a weaker brew, brew to regular strength, and then dilute with hot water to maximize the flavor and minimize bitterness.

Brew With Quality Water

Using quality water is essential in making quality coffee. In some cases, local tap water may be of low quality, which can negatively affect the flavor of the coffee. If your tap water is of poor quality, you may want to consider brewing your coffee using bottled water, or water from an under-sink Reverse Osmosis filtration system. However, do not use distilled or mineral water as this may damage your Coffee Maker.

Keeping Your Coffee Maker Clean

To maintain quality coffee flavor, it is important to keep your carafe and brew basket clean. After each use thoroughly wash these items.

Occasionally, it will be necessary to clean the entire system using a solution of vinegar and water (Read the Self Cleaning Instructions on page 6). Depending on the amount of use, it may be necessary to use this cleaning method once or twice a month.

Cleaning The Coffee Maker

- 1** Remove the Filter Basket and carafe from the Coffee Maker.
- 2** Wash the filter basket and Permanent Gold-Tone filter in hot, soapy water and rinse with hot water. Do not use abrasive cleansers or scouring pads. These parts can also be washed in the upper rack of a dishwasher.
- 3** Unplug the Coffee Maker and wipe the housing with a warm, damp cloth. Then wipe clean with damp cloth and dry with a soft cloth. Do not use abrasive cleansers or scouring pads. To brighten and clean the stainless steel exterior, Frigidaire recommends Ecosential Stainless Steel Cleaner by Smart Choice™. Purchase online at <http://frigidaire.stores.yahoo.net/> or call Toll-free number: 1-800-599-7569

Troubleshooting

- If the unit does not turn on, check to make sure that it is plugged into a grounded electrical outlet and that the circuit breaker is closed for that outlet. If the unit still fails to turn on, consult the warranty at the back of this Use & Care Guide for obtaining information on service.
- If the unit only brews a portion of the water placed in the reservoir, then it requires cleaning as described in the cleaning section of this Use & Care Guide.

SMALL DOMESTIC APPLIANCE WARRANTY INFORMATION

Your appliance is covered by a **one year limited warranty**. For one year from your original date of purchase, Electrolux will repair or replace the appliance or parts, at Electrolux's option, that prove to be defective in materials or workmanship when the appliance is installed, used, and maintained in accordance with the provided instructions. Labor and all costs associated with returning the appliance or parts to us and our returning the appliance or parts to you are excluded under this warranty. As a matter of warranty policy, Electrolux will not refund the consumer's purchase price. If a product or part under warranty is no longer available, Electrolux will replace with a comparable product of equal or greater value.

Exclusions: This warranty does not cover the following:

- 1 Products with original serial numbers that have been removed, altered or cannot be readily determined.
- 2 Products that have been transferred from the original owner to another party or removed outside the USA or Canada.
- 3 Rust on the interior or exterior of the unit.
- 4 Products purchased "as-is".
- 5 Food loss due to product failure.
- 6 Products used in a commercial setting or anything but single family household use.
- 7 Labor or service visits under any circumstance.
- 8 Glass parts or containers, filters, non-stick surfaces.
- 9 Ordinary wear and tear.
- 10 Damages caused by improper use, installation, or service; use of parts other than genuine Electrolux parts; negligence; abuse; misuse; inadequate or excessive power supply; accidents; fires; or acts of God.

Keep your receipt or some other appropriate payment record to establish the warranty period. Should warranty service be required, you must show proof of purchase.

If You Need Service:

To obtain warranty service in the USA or Canada, call 1-888-845-7330. Please have the model number, serial number, and date of purchase information available.

DISCLAIMER OF IMPLIED WARRANTIES; LIMITATION OF REMEDIES:

CUSTOMER'S SOLE AND EXCLUSIVE REMEDY UNDER THIS LIMITED WARRANTY SHALL BE, AT ELECTROLUX'S SOLE DISCRETION, PRODUCT OR PART REPAIR OR REPLACEMENT AS PROVIDED HEREIN. CLAIMS BASED ON IMPLIED WARRANTIES, INCLUDING WARRANTIES OF

MERCHANTABILITY OR FITNESS FOR A PARTICULAR PURPOSE, ARE LIMITED TO ONE YEAR OR THE SHORTEST PERIOD ALLOWED BY LAW. ELECTROLUX SHALL NOT BE LIABLE FOR CONSEQUENTIAL OR INCIDENTAL DAMAGES SUCH AS PROPERTY DAMAGE AND INCIDENTAL EXPENSES RESULTING FROM ANY BREACH OF THIS WRITTEN LIMITED WARRANTY OR ANY IMPLIED WARRANTY. SOME STATES AND PROVINCES DO NOT ALLOW THE EXCLUSION OR LIMITATION OF INCIDENTAL OR CONSEQUENTIAL DAMAGES, OR LIMITATIONS ON THE DURATION OF IMPLIED WARRANTIES, SO THESE LIMITATIONS OR EXCLUSIONS MAY NOT APPLY TO YOU. THIS WRITTEN WARRANTY GIVES YOU SPECIFIC LEGAL RIGHTS. YOU MAY ALSO HAVE OTHER RIGHTS THAT VARY FROM STATE TO STATE.

This warranty only applies to products purchased in the USA and CANADA. In the USA, your appliance is warranted by Electrolux Home Care Products, Inc. In Canada, your appliance is warranted by Electrolux Home Care Products Canada Inc. Electrolux authorizes no person to change or add to any obligations under this warranty. Product features or specifications as described or illustrated are subject to change without notice.

USA

1-888-845-7330

Electrolux Home Care Products, Inc.
10200 David Taylor Drive
Charlotte, NC 28262

CANADA

1-888-845-7330

Electrolux Home Care Products Canada Inc.
5855 Terry Fox Way
Mississauga, ON, Canada L5V 3E4