

COUNTER-DEPTH REFRIGERATOR

EW23CS75QS

Featuring Wave-Touch® Electronic Controls



PRODUCT DIMENSIONS

Height	69-1/2"
Width	35-5/8"
Depth	28-3/16"

MORE EASY-TO-USE FEATURES

WAVE-TOUCH® CONTROLS

One simple touch and the control panel activates, showing your refrigerator options. After you make your choices, all but the options selected will fade away, returning to an elegant display.

ENHANCED LIGHTING

Bright lighting makes finding food easy.

9"-TALL WATER/ICE DISPENSER

Our tall water and ice dispenser is specially designed to accommodate a variety of large containers, from a 16-ounce tumbler to a pitcher or a coffee carafe.

FAST FREEZE™

Freezes food faster to lock in freshness.

FAST ICE™

Makes ice up to 50% faster.

FROST-FREE DESIGN

The freezer defrosts itself so you don't have to.

AUTOMATIC ICE MAKER

Ensures you'll always have extra ice on hand.

STYLISH EXTERIOR

Signature Electrolux style: soft-arc door, stainless steel and blue LED displays.

PUREADVANTAGE® AIR FILTER

Keeps clean, filtered air circulated throughout to prevent odour transfer.

PUREADVANTAGE® WATER FILTER

Ensures fresh, clean water and ice at your fingertips.

FROZEN PIZZA SHELF

Conveniently located for easy access.

DIGITAL EXTERIOR CONTROL CENTRE

Lockable display shows vital functions, including temperature. Choose from Fahrenheit or Celsius display.

SIGNATURE FEATURES



LUXURY-GLIDE® CHILL ZONE™ DRAWER

Chilled air is vented directly into this Luxury-Glide® Drawer to keep the contents extra cold.



LUXURY-CLOSE™ DUAL HUMIDITY-CONTROLLED CRISPER DRAWER

Dual-Humidity Controlled crisper drawers keep fruits & vegetables fresher with self-closing drawers that lock in freshness and extend effortlessly. Its divider and dual controls provide the option to simultaneously store fruits and vegetables at their ideal humidity levels.



LUXURY-DESIGN® LIGHTING

Our ramp-up designer LED lighting is as beautiful as it is functional.



MORE COUNTER-DEPTH STORAGE

Our counter-depth refrigerator offers the same shelf space as a standard-depth refrigerator.

Available in:



Stainless
(S)

COUNTER-DEPTH REFRIGERATOR

EW23CS75QS



23 CU.FT. COUNTER-DEPTH REFRIGERATOR

CAPACITIES

Total Capacity	22.16 Cu. Ft.
Fresh Food Volume	14.17 Cu. Ft.
Freezer Volume	7.99 Cu. Ft.
Total Shelf Area	21.56 Sq. Ft.
Fresh Food Shelf Area	15.60 Sq. Ft.
Freezer Shelf Area	5.96 Sq. Ft.

EXTERIOR

Signature Soft-Arc Door and Handle Design	Yes
Electronic Controls	Wave-Touch®
Hidden Hinge Door Design	Yes
Ice/Water Dispenser	Yes
Perfect Set® Temperature Control System and Display	Yes
Crushed / Cubes / Water	Yes / Yes / Yes
Air and Water Filter Indicator / Reset	Yes
Fast Ice™ / Fast Freeze™	Yes / Yes
Lock / Dispenser Light Control	Yes / Yes

FRESH FOOD CONVENIENCES

PureAdvantage® Water & Ice	Yes
PureAdvantage® Air Filtration	Yes
Water Filter Location	Rear Right
Temp Alarm System	Yes
Door Ajar Alarm / Power Failure Alarm	Yes / Yes
Glass Shelves	3 Luxury-Design® Lift-Off
Dual Humidity-Controlled Upper Crisper	Luxury-Close™
Humidity-Controlled Lower Crisper	Luxury-Close™
Perfect Temp® Drawer	
Chill Zone™ Drawer	Luxury-Glide®
Wine and Beverage Mat	Yes
Clear Gallon Door Bins	
Clear 2-Litre Door Bins	1 Adjustable
Condiment Bin	1
Perfect Bin™ Door Storage	Yes
Dairy Compartment with Clear Cover	Yes
Tall Bottle Retainers	
Clear In-Door Can Racks (Holds 6 Cans Each)	1
Luxury-Design® LED Ramp-Up Multilevel	Yes

FREEZER CONVENIENCES

Automatic Ice Maker with Ice Server	Yes
Glass Shelves	2
Sliding Full-Width Freezer Baskets	1 Luxury-Glide® / 1 Standard
Sliding Half-Width Freezer Baskets	1
Clear Fixed Door Bins	3
Tilt-Out Wire Door Racks	
Ice Cream Shelf	Yes
Soft Freeze™ Bin	Yes
Pizza Shelf	Yes
Luxury-Design® LED Ramp-Up Multilevel	Yes

ADDITIONAL FEATURES

ENERGY STAR®	
Sabbath Mode (Star-K® Certified)	Yes

SPECIFICATIONS

Colour –	
Stainless Steel	S
Power Supply Connection Location	Right Bottom Rear
Water Inlet Location	Left Bottom Rear
Voltage Rating	120V / 60 Hz / 15A
Connected Load (kW Rating) @ 120 Volts†	1.02
Minimum Circuit Required (Amps)	15
Shipping Weight (Approx.)	325 Lbs.

†An electrical supply with grounded three-prong receptacle is required. The power supply circuit must be installed in accordance with national and local codes & ordinances.

NOTE: Always consult local and national electric and plumbing codes. Refer to Product Installation Guide for detailed installation instructions on the web at electroluxappliances.ca.

Specifications subject to change.

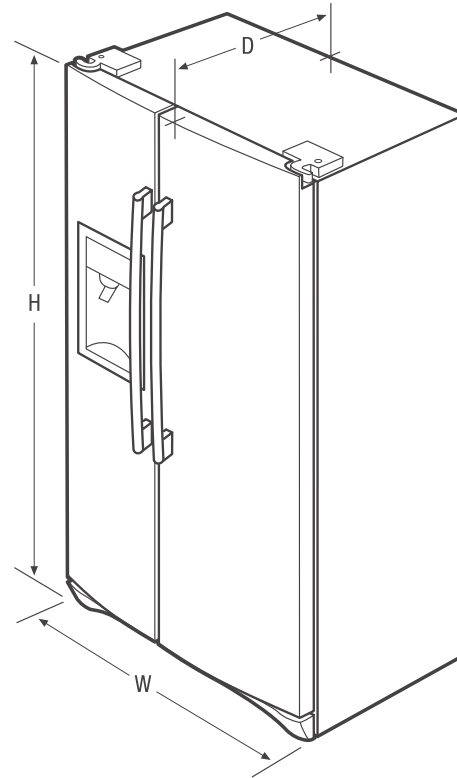

PRODUCT DIMENSIONS

Height (With Hinges and 3/8" Rollers) (Including Door)	69-1/2" 70-1/8"
Width	35-5/8"
Depth (Including Door) (with Door 90° Open)	28-3/16" 45"



Electrolux Major Appliances, N.A.

CANADA • 5855 Terry Fox Way • Mississauga, ON L5V 3E4 • 1-800-265-8352 • electroluxappliances.ca

EW23CS75Q 05/15

© 2015 Electrolux Major Appliances, N.A.

High standards of quality at Electrolux Home Products, Inc. mean we are constantly working to improve our products. We reserve the right to change specifications or discontinue models without notice.

Printed in Canada