

# Apartment Refrigerator

FFHT10F2LW

10 Cu. Ft. Top Mount



## Product Dimensions

Height	59-3/4"
Width	23-3/4"
Depth (Including Door)	26-3/4"
Depth with Door Opened 90°	48-1/32"

## More Easy-To-Use Features

### Ready-Select® Controls

### Store-More™ Built-In Can Dispenser

Convenient in-door can storage.

### Bright Lighting

Our bright lighting makes it easy to see what's inside.

### Square Door Design

### Colour-Coordinated Door Handle (Recessed)

### Colour-Coordinated Smooth Cabinet Finish

### Colour-Coordinated Door Hinge Covers

### Reversible Door-Swing Option

Door can be installed to open left or right based on your needs.



ENERGY STAR®

Available in:



White  
(W)

## Signature Features

### Store-More™ Freezer

Easy-to-access freezer includes a shelf and door rack.

### Store-More™ Clear Crisper Drawers

Keep your fruits and vegetables fresh in our crisper drawers.

### SpaceWise® Adjustable Wire Shelves

Easily adjust shelves up and down to create more space for taller items.

### Store-More™ Door Bins

Door bins provide ample storage.

Features	
Cubic Feet (Cu.Ft.)	10
Exterior	
Door Colour	Colour-Coordinated
Cabinet Colour	Colour-Coordinated
Door Handle	Integrated
Door Stops	Yes
Reversible Door	Yes
Interior	
Controls	Ready-Select*
Lighting	Bright LED
Refrigerator Shelves	2 SpaceWise® Adjustable Wire
Store-More™ Crisper Drawers	2 Clear
Door Bins	3 Half-Width Clear
Door Racks	1 Full-Width Clear
Tall Bottle Storage	Yes
Can Rack	3-Can Capacity
Freezer Racks	2 Full-Width Clear
Freezer Shelves	1 SpaceWise® Adjustable Wire
Cabinet Liner	White
Certifications	
ENERGY STAR®	Yes
Specifications	
Total Capacity (Cu.Ft.)	9.9
Refrigerator Capacity (Cu.Ft.)	7.09
Freezer Capacity (Cu.Ft.)	2.88
Power Supply Connection Location	Right Bottom Rear
Voltage Rating	120V / 60Hz / 15 or 20A
Minimum Circuit Required (Amps)	15
Shipping Weight (Approx.)	154 Lbs.
Installation Type	Freestanding

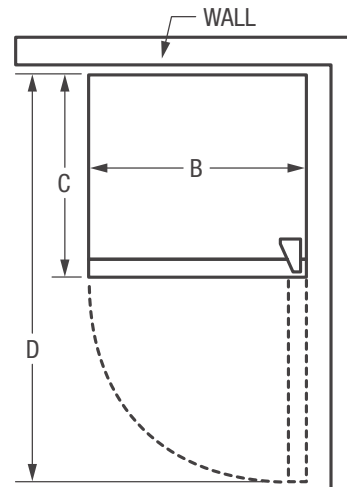
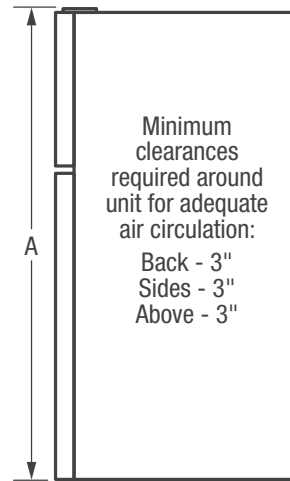

NOTE: For planning purposes only. Always consult local and national electric codes. Refer to Product Installation Guide for detailed installation instructions on the web at [frigidaire.ca](http://frigidaire.ca).



Product Dimensions	
A - Height	59-3/4"
B - Width	23-3/4"
C - Depth (Incl. Door)	26-3/4"
D - Depth with Door Open 90°	48-1/32"

Accessories information available on the web at [frigidaire.ca](http://frigidaire.ca)