



# Top Mount Refrigerator

FPH1888PF

18 Cu. Ft. Top Mount



## Product Dimensions

Height (Including Hinges & Rollers)	66-5/8"
Width	30"
Depth	30-1/8"

## More Easy-To-Use Features

### SpillSafe® Shelves

Designed to keep spills contained, making cleanup a breeze.

### Full-Width Cool Zone™ Drawer

Offers you another storage option that is conveniently located so you have easy access to foods such as deli meat and cheeses.

### Reversible Door

Door can be installed to open left or right based on your needs.

### Quick Find Door Bin

Store your most-used items in one convenient location. Removable design allows you to carry it to the table at mealtimes, making cleanup a breeze.

### Clear Dairy Door

## Signature Features



### SpaceWise® Organization System

Our SpaceWise® Organization System makes it easy to keep food organized and easy to find when you need it.



### Humidity-Controlled Crisper Drawers

Keep your fruits and vegetables fresh in our humidity-controlled crisper drawers.



### Smudge-Proof™ Stainless Steel

Reduces fingerprints and smudges so it's easy to clean.



### Bright Lighting

Our bright lighting makes it easy to see what's inside.



ENERGY STAR®

Available in:



Stainless  
(F)

Features	
Door Design	UltraSoft™
Door Handle Design	Stainless Steel
Cabinet Finish (Textured)	Grey
Door Stops	Yes
Door Hinge Covers	Grey
Door Reverse Option	Yes
Rollers - Front/Rear	Adjustable/ Yes
Sound Package	Quiet Pack
Toe Grille	Grey
Refrigerator Features	
Interior Lighting	Bright
Refrigerator Shelves	3 Sliding SpillSafe® Adjustable Glass
Cool Zone™ Drawer	Full-Width Clear
Wine/Can Rack	White
Store-More™ Crisper Drawers	2 Clear
Humidity Controls	2
Dairy Compartment	Clear Dairy Door
Door Bins	1 Quick-Find, 3 Adj. Half-Width Clear, 1 Fixed Full-Width White
Door Racks	
Non-Slip Bin Liner	3
Tall Bottle Retainers	Yes
Gallon Door Storage	3
Freezer Features	
Door Bins	1 Full-Width Clear
Door Racks	1 Tilt-Out Full-Width Wire
Freezer Shelves	1 Full-Width Glass w/ Sliding Wire Under-Basket
Factory Ice Maker w/ Large Ice Bin	Included (PN# IM115)
Lighting	Yes
Certifications	
ENERGY STAR®	Yes
Specifications	
Total Capacity (Cu. Ft.)	18.3
Refrigerator Capacity (Cu. Ft.)	14.2
Freezer Capacity (Cu. Ft.)	4.1
Power Supply Connection Location	Right Bottom Rear
Water Inlet Connection Location	Bottom Right
Voltage Rating	120V / 60Hz / 15 or 20A
Connected Load (kW Rating) @ 120 Volts¹	0.72
Amps @ 120 Volts	6.0
Minimum Circuit Required (Amps)	15
Shipping Weight (Approx.)	205 Lbs.

<sup>1</sup>For use on adequately wired 120V, dedicated circuit having 2-wire service with a separate ground wire. Appliance must be grounded for safe operation.

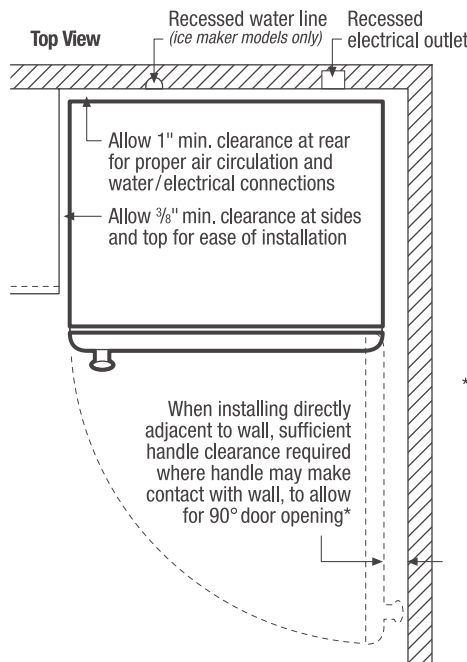
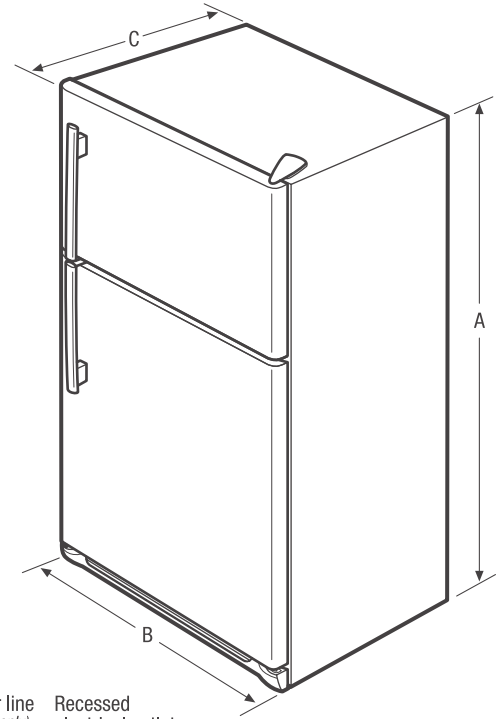

\* When installing refrigerator adjacent to wall, cabinet or other appliance that extends beyond front edge of unit, 20" minimum clearance recommended to allow for optimum 140° door swing, providing complete crisper access and removal. (Absolute 3" minimum clearance will ONLY allow for 90° door swing which will provide limited crisper access with restricted removal.)

NOTE: For planning purposes only. Always consult local and national electric and plumbing codes. Refer to Product Installation Guide for detailed installation instructions on the web at [frigidaire.ca](http://frigidaire.ca).



Product Dimensions	
A - Height (Incl. Hinges & Rollers)	66-5/8"
B - Width	30"
C - Depth (Incl. Door)	30-1/8"
Depth with Door Open 90°	58-1/2"

Accessories information available on the web at [frigidaire.ca](http://frigidaire.ca)